



ADG-630 Service Manual

24 VAC Phase 5

Dual Microprocessor Controller (DMC)
Mechanical/Electrical

American Dryer Corporation
88 Currant Road
Fall River, MA 02720-4781
Telephone: (508) 678-9000 / Fax: (508) 678-9447
E-mail: techsupport@amdry.com

Retain This Manual In A Safe Place For Future Reference

American Dryer Corporation products embody advanced concepts in engineering, design, and safety. If this product is properly maintained, it will provide many years of safe, efficient, and trouble-free operation.

ONLY qualified technicians should service this equipment.

OBSERVE ALL SAFETY PRECAUTIONS displayed on the equipment or specified in the installation/operator's manual included with the dryer.

The following “**FOR YOUR SAFETY**” caution **must be** posted near the dryer in a prominent location.

FOR YOUR SAFETY

Do not store or use gasoline or other flammable vapors or liquids in the vicinity of this or any other appliance.

POUR VOTRE SÉCURITÉ

Ne pas entreposer ni utiliser d'essence ni d'autres vapeurs ou liquides inflammables dans le voisinage de cet appareil ou de tout autre appareil.

We have tried to make this manual as complete as possible and hope you will find it useful. **ADC** reserves the right to make changes from time to time, without notice or obligation, in prices, specifications, colors, and material, and to change or discontinue models.

Important

For your convenience, log the following information:

DATE OF PURCHASE _____ MODEL NO. **ADG-630** _____
DISTRIBUTORS NAME _____
Serial Number(s) _____

Replacement parts can be obtained from your distributor or the **ADC** factory. When ordering replacement parts from the factory, you can FAX your order to **ADC** at (508) 678-9447 or telephone your orders directly to the **ADC** Parts Department at (508) 678-9000. Please specify the dryer **model number** and **serial number** in addition to the **description** and **part number**, so that your order is processed accurately and promptly.

The illustrations on the following pages may not depict your particular dryer exactly. The illustrations are a composite of the various dryer models. Be sure to check the descriptions of the parts thoroughly before ordering.

“IMPORTANT NOTE TO PURCHASER”

Information must be obtained from your local gas supplier on the instructions to be followed if the user smells gas. These instructions must be posted in a prominent location near the dryer.

IMPORTANT

YOU MUST DISCONNECT and LOCKOUT THE ELECTRIC SUPPLY and THE GAS SUPPLY or THE STEAM SUPPLY BEFORE ANY COVERS or GUARDS ARE REMOVED FROM THE MACHINE TO ALLOW ACCESS FOR CLEANING, ADJUSTING, INSTALLATION, or TESTING OF ANY EQUIPMENT per OSHA (Occupational Safety and Health Administration) STANDARDS.

FOR YOUR SAFETY

DO NOT STORE OR USE GASOLINE OR OTHER FLAMMABLE VAPOR AND LIQUIDS IN THE VICINITY OF THIS OR ANY OTHER APPLIANCE.

DO NOT DRY MOP HEADS IN THE DRYER.

DO NOT USE DRYER IN THE PRESENCE OF DRY CLEANING FUMES.

CAUTION

DRYERS SHOULD NEVER BE LEFT UNATTENDED WHILE IN OPERATION.

WARNING

CHILDREN SHOULD NOT BE ALLOWED TO PLAY ON OR NEAR THE DRYERS.

CHILDREN SHOULD BE SUPERVISED IF NEAR DRYER(S) IN OPERATION.

WARNING

The dryer must never be operated with any of the back guards, outer tops, or service panels removed. PERSONAL INJURY or FIRE COULD RESULT.

IMPORTANT

PLEASE OBSERVE ALL SAFETY PRECAUTIONS displayed on the equipment or specified in the installation and operator's manual included with the dryer.

Dryers **must not** be installed or stored in an area where it will be exposed to water or weather.

The wiring diagram for the dryer is located in the front electrical control box area.

Table of Contents

SECTION I

Routine Maintenance	3
A. Cleaning	3
B. Adjustments	4
C. Lubrication	4

SECTION II

Mechanical Section	5
A. To Remove Lint Drawer	5
B. To Remove Control (Middle) or Lint (Lower) Door	5
C. To Remove Gas Valve Train Assembly	5
D. To Remove Control Box	6
E. To Remove Front Panel	6
F. To Remove and Replace Lint Drawer Switch Assembly	6
G. To Remove and Replace Sensor Bracket and Components	7
H. To Remove or Replace Belt	8
I. To Remove or Replace Motor	10
J. To Remove or Replace Impellor (Fan)	13
K. Belt and Idler Tension Adjustment	13
L. Fan Belt and Tension Adjustment	14
M. To Remove Dual Control Microprocessor (DMC) Computer Panel Assembly	14
N. To Replace Dual Control Microprocessor (DMC) Computer	14
O. To Replace Touchpad (Keypad)	15
P. To Replace Coin Acceptor	15
Q. To Replace either Motor Relay	16
R. Basket (Tumbler) Alignment - Vertical	16
S. Basket (Tumbler) Alignment - Lateral	17
T. To Replace Basket (Tumbler) or Basket (Tumbler) Support	18
U. To Replace Basket (Tumbler) Support Pillow Block Bearing	20
V. To Replace Basket (Tumbler) Support Flange Bearing	22
W. To Replace 330° F (burner) Hi-Limit Switch (thermostat)	23
X. To Replace Sail Switch	24
Y. To Replace Main Door Switch	24
Z. To Replace Direct Spark Ignition (DSI) Module	24
AA. To Replace Ignitor and Probe	25
BB. To Replace Gas Valve	25
CC. To Convert Dryer from Natural Gas to Liquid Propane (L.P.) Gas	25
DD. To Replace Coin Vault	26
EE. To Remove Main Door	27
FF. To Install New Main Door Glass	27
GG. To Replace Main Door Gasket	27
HH. To Replace Main Door Hinge	27

SECTION III

Troubleshooting	28
------------------------------	----

SECTION IV

Electrical Troubleshooting 34

SECTION V

Technical Information 39

A. Data Label 39

B. Using Manometer 40

C. L.E.D. Display Codes 41

SECTION VI

Phase 5 (L.E.D. Display) Failure Codes 43

A. Diagnostic (L.E.D. Display) Failure Codes 43

B. L.E.D. Display Indicators (DOT) 44

C. Phase 5 DMC (Computer) Relay Output L.E.D. Indicators 44

D. Phase 5 DMC (Computer) Input and Output L.E.D. Indicators 45

E. Phase 5 Microprocessor Controller Programming Limits 46

SECTION I

ROUTINE MAINTENANCE

A. Cleaning

A program or schedule should be established for periodic inspection, cleaning, and removal of lint from various areas of the dryer, as well as, throughout the duct work system. The frequency of cleaning can best be determined from experience at each location. Maximum operating efficiency is dependent upon proper air circulation. The accumulation of lint can restrict this air flow. If the guidelines in this section are met, your new dryer will provide many years of efficient, trouble-free, and - most importantly - safe operation.

WARNING: LINT FROM MOST FABRICS IS HIGHLY COMBUSTIBLE. THE ACCUMULATION OF LINT CAN CREATE A POTENTIAL FIRE HAZARD.

WARNING: KEEP DRYER AREA CLEAR AND FREE FROM COMBUSTIBLE MATERIALS, GASOLINE, AND FLAMMABLE VAPORS AND LIQUIDS.

NOTE: SUGGESTED TIME INTERVALS SHOWN ARE FOR AVERAGE USAGE WHICH IS CONSIDERED SIX (6) TO EIGHT (8) OPERATIONAL RUNNING HOURS PER DAY.

DAILY (beginning of each work shift)

Clean lint from basket and tumbler.

Inspect lint screen and drawer for damage and replace it if torn.

WEEKLY

Clean lint accumulation from around microprocessor temperature sensor probes and sensor bracket assemblies.

90 DAYS

Remove lint from air vents and surrounding area.

IMPORTANT: Lint accumulation will restrict the air flow over the motor, causing overheating and irreparable motor damage. Motor failure due to lint accumulation will **VOID THE WARRANTY.**

Remove lint accumulation from around the openings in the dryer's back panels.

Remove lint from gas valve burner train area with a dusting brush or vacuum cleaner attachment.

Remove any lint accumulation from coin acceptor, including the optical switch.

Inspect and remove lint accumulation in customer-furnished exhaust duct work system and from the dryer's internal exhaust ducting.

**WARNING: THE ACCUMULATION OF LINT IN THE EXHAUST DUCT WORK
CAN CREATE A POTENTIAL FIRE HAZARD.**

6 MONTHS

In the cleaning of the dryer cabinet, avoid using harsh abrasives. A product for the cleaning of appliances is recommended.

B. Adjustments

Seven (7) Days After Installation and Every 6 Months Thereafter

Inspect bolts, nuts, screws (bearing set screws), nonpermanent gas connections (unions, shut-off valves, orifices, etc.), electrical terminations, and grounding connections.

The 12-Rib 95" (J) poly belt arrangement should be examined. A cracked or seriously frayed belt should be replaced. Tighten loose belts when necessary and check the alignment.

Complete operational check of controls and valves.

Complete operational check of all safety devices (door switches, lint compartment switches, sail switches, burner and hi-limit thermostats).

C. Lubrication

The motor bearings, idler bearings and tumbler bearings are permanently lubricated. No lubrication is necessary.

SECTION II

MECHANICAL SECTION

A. To Remove Lint Drawer

1. Pull out lint drawer three quarters of the way (approximately twenty inches).
2. Reach up into the back of the lint drawer and pull down the retainer (hinge) that is attached to the top of the lint drawer.
3. The lint drawer can now be removed.
4. Reverse procedure for reinstalling the lint drawer.

B. To remove control (middle) or lint (lower) door

1. Pull out lint drawer three quarters of the way (approximately twenty (20) inches). Reach into the back of the lint drawer and push down the retainer (hinge) that is attached to the top of the lint drawer.
2. Pull out the lint drawer.
3. Open the control and lint door (2) 1/4 turn locks, one (1) on each side.
4. Remove the control and lint door.
5. Reverse procedure for reinstalling the control and lint door.

C. To remove gas valve train assembly

1. Discontinue power to the dryer.
2. Close all gas shut-off valves in the gas supply line to the dryer.
3. Remove the lint drawer and the control and lint door from the dryer. Follow lint drawer and control and lint door removal procedures in section A and B.
4. Close the union shut-off valve at inlet area of the gas valve.
5. Loosen the union shut-off valve collar nut all the way.
6. Pull out gas valve train assembly 1/4 of the way. Disconnect the gas harness power connector at the top of the assembly.
7. Gently pull and remove the gas valve train assembly.

IMPORTANT: When removing the gas valve train assembly be careful not to snag or damage the gas valve train wiring disconnected in step 6.

8. Reverse procedure for reinstalling the gas valve train assembly.

NOTE: Be sure to open all gas shut-off valves closed prior to removing the gas valve train assembly.

9. Reestablish power to the dryer.

D. To Remove Control Box

1. Discontinue power to the dryer.
2. Remove the lint drawer and the control door from the dryer. Follow lint drawer, and control and lint door removal procedures in sections A and B.
3. Remove screw located on the bottom right-hand corner of the control panel.
4. Slide out the control box and hang the control box assembly on hinges located on the right side panel, and disconnect the three (3) wiring harnesses (connectors) at the back of the control box.
5. The control box may now be taken out of the dryer completely or depending on the service function to be performed, the box can be attached to the two (2) female hinges on the right side of the dryer cabinet.

NOTE: If the control box is attached to the dryer cabinet, the three (3) wiring harnesses mentioned in *step #4* do not need to be disconnected.

6. Reverse procedure for reinstalling the control box assembly.
7. Reestablish power to the dryer.

E. To Remove Front Panel

1. Discontinue power to the dryer.
2. Remove the control box assembly. Follow control box removal procedure in section D.
3. If the bottom front panel is being removed, the lower lint door must also be removed.
4. Disconnect the door switch connector from the lint drawer switch box assembly located under the basket.

NOTE: There are two (2) harnesses that connect to the lint drawer switch box. Locate and disconnect the one that leads to the front panel.

5. Pull up the two (2) metal fingers where the door switch harness is secured to the frame and right side panel of the dryer.
6. Remove all nine (9) screws from the front panel. There are four (4) on the left and right sides, and one (1) at the bottom of the panel behind the control door.
7. Gently remove the front panel assembly from dryer.
8. Reverse procedure for reinstalling front panel assembly.
9. Reestablish power to the dryer.

F. To Remove and Replace Lint Drawer Switch Assembly

1. Discontinue power to the dryer.
2. Remove the lint drawer, and the control and lint door from the dryer. Follow lint drawer, and control and lint door removal procedures in sections A and B.
3. If top basket (tumbler) is being serviced, remove the control box assembly. Follow control box removal procedure in section D.

4. To remove the lint drawer switch box assembly, remove the two (2) screws inside the lint drawer area that secure the box to the side of the lint coop.
5. Disassemble lint drawer box assembly from the dryer by disconnecting the two (2) harness connectors from the box assembly.
6. Remove the two (2) phillips head screws securing the cover to the switch mounting bracket.
7. Disassemble the switch from the box by removing the two (2) slotted head screws securing the switch to the bracket and disconnect the terminals from the switch.
8. Reverse procedure for reinstalling the lint drawer switch assembly.
9. Reestablish power to the dryer.

G. To Remove and Replace Sensor Bracket and Components

1. Discontinue power to the dryer.
2. Remove the lint drawer, and the control and lint door from the dryer. Follow lint drawer, and control and lint door removal procedures in **sections A and B**.
3. Pull the front of the sensor bracket forward to remove it from the "S" clips. Pivot bracket downward and assembly will separate from the sensor bracket holder.
4. To disassemble bracket assembly from dryer, disconnect the two (2) harness connectors.
5. To remove the temperature sensor and the connecting harness with its connectors:
 - A. Disassemble microprocessor sensor probe from the bracket by removing the 1/4" push-on fastener from the outside of the bracket.
 - B. Remove harness connectors by squeezing sides and pushing towards the center of the bracket.
 - C. Disconnect the two (2) wires from the 170° thermostat.
 - D. Reverse procedure for installing new sensor probe assembly.
6. To replace the 170° thermostat:
 - A. Remove the two (2) slotted head screws, washers, and nuts securing the 170° thermostat at the bracket assembly.
 - B. Reverse procedure for installing new 170° thermostat.

7. Reverse procedure for reinstalling power to the dryer.

IMPORTANT: When reinstalling the sensor bracket assembly to the dryer, be sure the internal wires do not get pinched between the sensor bracket and the holder.

8. Reestablish power to the dryer.

H. To Remove or Replace Belt

1. Discontinue power to the dryer.
2. Remove the lint drawer and the control and lint door from dryer.
3. If top basket (tumbler) is being serviced, remove control box assembly and belt guard from idler arm. Follow control box remove procedure in **sections A and B**.
4. Remove panel from basket (tumbler) being serviced. Follow from panel removal procedure in **section E**.
5. Loosen the tension on the idler arm adjusting spring by loosening the two (2) 9/16" nuts on the spade bolt.
6. Remove the motor pulley from the shaft. This can be done by rolling the fan belt off the pulley. Then loosen the set screw of the motor pulley and slide the pulley off the shaft.
7. Slide belt off the idler bracket and motor shaft.
8. Push belt up into basket (tumbler) area through the brushes and opening in the wrapper.
9. Remove the belt by maneuvering it back and forth and sliding it forward with your hands up through the lint drawer area.
10. The belt will come out from the front of the dryer between the basket (tumbler) and the wrapper.
11. Reverse procedure for installing new belt.

IMPORTANT: Be sure to set proper belt tension at idler adjustment. Follow belt and idler tension adjustment procedure in **section K**.

12. Reestablish power to the dryer.

LOCTITE®

LOCTITE® is being used on ALL small dryers (AD-15 through 81 including stack dryers) that are manufactured by ADC. LOCTITE® is being applied to ALL bearing set screws, used on ALL basket (tumbler) shafts, ALL idler shafts, ALL impeller (fan and blower) shafts, and ALL drive shaft bearings.

IMPORTANT
LOCTITE® ADHESIVE HAS BEEN USED
TO SECURE SET SCREWS AND BEARINGS
IN PLACE, ONCE SET SCREWS HAVE BEEN
REMOVED, A GEAR PULLER MAY BE NECESSARY
TO REMOVE BEARING TO AVOID DAMAGE.

P/N 112801

One (1) of these labels is attached to each Basket (tumbler) Bearing Assembly (pillow block bearing box). On the ADG-630 dryer this label is affixed near the small Impeller (fan) Shaft Bearing.

Should readjustments or removal of set screws become necessary in the field and the process becomes difficult, apply heat to the set screw with a soldering gun (450° F) for a few minutes.

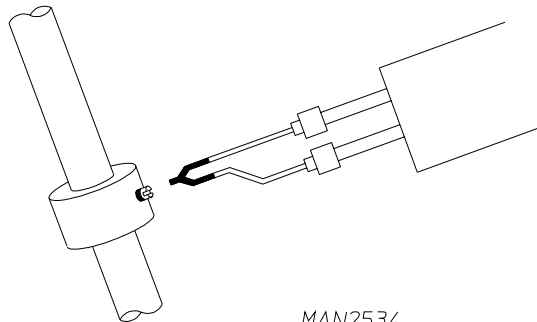

IMPORTANT: Readjustment and removal of the Impellor (fan) Shaft bearings using Green LOCTITE® (#609) require that the bearing itself be heated.
In lieu of heating, ADC recommends the replacement of these assemblies in order to provide a true fit and avoid any warpage upon reinstallation.

NOTE: The application of LOCTITE® during the dryer manufacturing process *does not* preclude the recommended six (6) month interval that ADC advises for periodically checking ALL set screws within the dryer.

I. To Remove or Replace Motor

1. Discontinue power to the dryer.
2. Remove the lint drawer and the control door from the dryer. Follow control and lint door removal procedures in **sections A and B**.
3. If top basket (tumbler) is being serviced, remove the control box from the dryer. Follow control box removal procedure in **section D**.
4. Remove the two (2) 9/16" (O.D.) nuts that are on the idler tension spade bolt.
5. Remove the motor pulley from the shaft. This can be done by rolling the fan belt off the pulley. Then loosen the set screw of the motor pulley and slide the pulley off the shaft.
6. Remove drive belt from motor shaft.
7. Remove the two (2) bolts, lock washers, and washers in front of the motor mount.
8. Remove the lower half of the rear split back guard panel to either the top or the bottom basket (tumbler), depending on which basket (tumbler) is being serviced.
9. Remove the four (4) 7/16" (O.D.) nuts which secure the impellor (fan) cover to the blower housing.
10. Remove the two (2) 7/16" (O.D.) nuts and lock washers which secure the impellor (fan) and shaft bearing to the impellor (fan) housing cover.
11. Loosen the two (2) set screws on the impellor (fan) and shaft bearing.
12. Remove the impellor (fan) and shaft bearing from the shaft. To do so, wedge a slotted screwdriver blade between the bearing and impellor (fan) cover and walk bearing back off shaft. The impellor (fan) cover will now separate from the blower (impellor and fan) housing.
13. Remove impellor (fan) lock nut (left hand) and lock washer securing impellor (fan) to fan shaft. This can be done by turning the lock nut to the left with an adjustable wrench, or more advisable, with a 1-1/8" deep socket ratchet wrench in an effort to avoid damaging the lock nut.
14. Align impellor (fan) to the center of the blower housing hole and remove impellor (fan) by grasping fan with both hands and pulling outward. The key will also come off the motor shaft in this procedure.
15. Return to the front of the dryer and disconnect the wiring harness from the motor.
16. Remove the motor through the front of the dryer take motor mount off motor (4 nuts, washers, lock washers).

NOTE: When replacing the motor use P/N 881599. This will come with a keyed motor shaft and a new pulley to accommodate the keyed shaft.

17. Reconnect the wiring harness disconnected from the motor in **step 15**.
18. Insert key into the motor shaft removed in **step 14**, line up keyway in impellor (fan) with key in the shaft and slide impellor (fan) all the way onto shaft.
19. Reinstall the lock washer and lock nut (right hand) removed in **step 13** and tighten securely.
20. Reassemble the impellor and shaft bearing to the impellor (fan) cover and secure (hand tighten only) with the two (2) nuts removed in **step 10**. Install the housing cover and bearing assembly onto the shaft and housing. Secure the two (2) set screws on the impellor (fan) and shaft bearing. Be sure that these set screws are securely in place.

20. Reassemble the impellor and shaft bearing to the impellor (fan) cover and secure (hand tighten only) with the two (2) nuts removed in **step 10**. Install the housing cover and bearing assembly onto the shaft and housing secure with four (4) nuts removed in **step 9**. Secure the two (2) set screws on the impellor (fan) and shaft bearing be sure that these set screws are securely in place.
20. Reassemble the impellor and shaft bearing to the impellor (fan) cover and secure (hand tighten only) with the two (2) nuts removed in **step 10**. Install the housing cover and bearing assembly onto the shaft and housing secure with the four (4) nuts removed in **step 9**. Secure the two (2) set screws on the impellor (fan) and shaft bearing be sure that these set screws are securely in place.
21. The impellor (fan) must now be adjusted or centered in the blower housing align the center of the motor shaft (at impellor [fan] or shaft bearing) so that the center of the motor shaft is **exactly** eight (8) inches from the left side panel.
 - A. Once the impellor (fan) is properly centered tighten the two (2) nuts of the impellor and shaft bearing that were hand tightened in **step 20**.

IMPORTANT: Failure to have the impellor (fan) properly aligned can result in the impellor (fan) being damaged.

22. Reinstall the lower half of the rear split back guard panel removed in **step 8**.
23. Replace the two (2) bolts, lock washers, and washers removed in **step 7**. Tighten bolts.
24. Assemble the two (2) 9/16" (O.D.) nuts onto idler tension spade bolt removed in **step 4**. Do not tighten these two (2) 9/16" nuts at this time.
25. Reconnect drive belt and motor pulley with fan belt and then make necessary belt tension adjustments. Follow belt and idler tension adjustment procedure in **section K**.
26. Make necessary impellor belt adjustments by tightening or loosening the 5/16" HEX head machine bolt on the side of the impellor bearing mount. Before making this adjustment the two (2) bolts in **step 23** must be loose. Retighten these bolts after proper alignment and tension adjustment is made for the belt impellor.
27. Reverse **steps 1** through **3**.

LOCTITE®

LOCTITE® is being used on ALL small dryers (AD-15 through AD-81 including stack dryers) that are manufactured by ADC. LOCTITE® is being applied to ALL bearing set screws, used on ALL basket (tumbler) shafts, ALL idler shafts, ALL impellor (fan and blower) shafts, and ALL drive shaft bearings.

IMPORTANT
LOCTITE® ADHESIVE HAS BEEN USED
TO SECURE SET SCREWS AND BEARINGS
IN PLACE, ONCE SET SCREWS HAVE BEEN
REMOVED, A GEAR PULLER MAY BE NECESSARY
TO REMOVE BEARING TO AVOID DAMAGE.

P/N 112801

One (1) of these labels is attached to each Basket (tumbler) Bearing Assembly (pillow block bearing box). On the ADG-630 dryer this label is affixed near the small Impellor (fan) Shaft Bearing.

Should readjustments or removal of set screws become necessary in the field and the process becomes difficult, apply heat to the set screw with a soldering gun (450° F) for a few minutes.

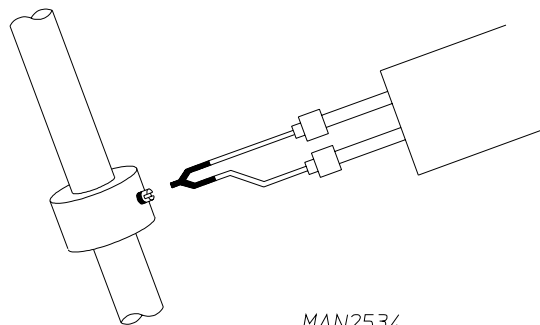

IMPORTANT: Readjustment and removal of the Impellor (fan) Shaft bearings using Green LOCTITE® (#609) require that the bearing itself be heated.
In lieu of heating, ADC recommends the replacement of these assemblies in order to provide a true fit and avoid any warpage upon reinstallation.

NOTE: The application of LOCTITE® during the dryer manufacturing process *does not* preclude the recommended six (6) month interval that ADC advises for periodically checking ALL set screws within the dryer.

J. To Remove or Replace Impellor (Fan)

1. Discontinue power to the dryer.
2. Remove the lower half of the rear split back guard panel to either the top or the bottom basket (tumbler), depending on which basket (tumbler) is being serviced.
3. Remove the four (4) 7/16" (O.D.) nuts which secure the impellor (fan) housing to the blower housing.
4. Remove the two (2) 7/16" (O.D.) nuts and lock washers which secure the impellor (fan) or shaft bearing to the impellor (fan) or shaft bearing to the impellor (fan) housing.
5. Loosen the two (2) set screws on the impellor (fan) or shaft bearing.
6. Remove the impellor (fan) or shaft bearing from the shaft, to do so, wedge a slotted screw driver blade between the bearing impellor (fan) cover and walk bearing back off of the shaft, the impellor (fan) cover will also now separate from the blower (fan) housing.
7. Remove the impellor lock nut (left hand) and remove the lock washer securing the impellor to the motor shaft. This can be done by turning the lock nut to the right with an adjustable wrench or more advisable, with a 1-1/8" deep socket ratchet wrench in an effort to avoid damaging the lock nut.
8. Align impellor (fan) to the center of the blower housing hole and remove impellor (fan) by grasping fan with both hands and pulling outward. The key will also come off motor shaft in this procedure.
9. To install impellor (fan), insert key into motor shaft removed in **step 10**. Line up key way in impellor (fan) with key in the shaft and slide impellor (fan) all the way onto shaft.
10. Reinstall the lock washer and lock nut removed in **step 9** and tighten securely.
11. Reassemble the impellor and shaft bearing to the impellor (fan) cover and secure (hand tighten only) with the two (2) nuts removed in **step 10**. Install the housing cover and bearing assembly onto the shaft and housing secure with the four (4) nuts removed in **step 9**. Secure the two (2) set screws on the impellor (fan) and shaft bearing. Be sure that these screws are securely in place.
12. The impellor (fan) **must now be** adjusted or centered in the blower housing. Align the center of the fan shaft (at the impellor [fan] and shaft bearing) so that the center of the fan shaft is **exactly** eight (8) inches from the left side panel.
 - A. Once the impellor (fan) is properly centered tighten the two (2) nuts of the impellor and shaft bearing that were hand tightened in **step 13**.

IMPORTANT: Failure to have the impellor (fan) properly aligned can result in the impellor (fan) being damaged.

13. Reinstall the lower half of the rear split back guard panel removed in **step 4**.

K. Belt and Idler Tension Adjustment

1. Discontinue power to the dryer.
2. Remove the lint drawer, the control and lint door, and the control box assembly from the dryer. Follow control box removal procedure in **section D**.

NOTE: If lower basket (tumbler) is being serviced, the control box **does not** have to be removed.

3. To adjust tension, while holding spade tension bolt in place, i.e. with channel lock pliers, loosen the 9/16" (O.D.) to adjust tension, loosen the 9/16" (O.D.) locking nut. To increase tension, loosen the inner nut.

NOTE: Approximate proper belt tension - when there is a one (1) inch space between the idler adjustment bracket and the first thread in the right hand side of the spade tension bolt.

NOTE: If lower basket (tumbler) is being serviced, the control box **does not** have to be removed.

3. To adjust tension, while holding spade tension bolt in place, i.e. with channel lock pliers, loosen the 9/16" (O.D.) to adjust tension, loosen the 9/16" (O.D.) locking nut. To increase tension, loosen the inner nut.
4. Once proper adjustment is achieved, secure the 9/16" locking nut.
5. Reverse **steps 1 and 2**.

L. Fan Belt and Tension Adjustment

1. Discontinue power to the dryer.
2. On the side of the fan shaft mount there is a 5/16-18 x 2" HEX head machine bolt that is used to adjust the tension of the fan belt.
3. Loosen the two HEX head bolts on the front of the motor mount that holds it to the fan shaft mount.
4. By turning the bolt mentioned in **step 2** you can now adjust the bolt tension. Tightening this bolt will increase the tension of the fan belt and loosening the bolt will decrease the tension.
5. When proper tension is achieved retighten the two (2) HEX head bolts loosened in **step 3**.
6. Reestablish power to the dryer.

M. To Remove Dual Control Microprocessor (DMC) Computer Panel Assembly

1. Discontinue power to the dryer.
2. Remove the lint drawer and the control door from the dryer. Follow lint drawer, and control and lint door removal procedures in **sections A and B**.
3. Remove screw in the lower right hand corner of the control panel securing the panel to the control box.
4. Open the control panel and disconnect all the harnesses that are connected to the dual microprocessor control (DMC) computer; the two (2) 9-pin wire harness connectors and the 4-pin connector wiring harness.
5. To remove the control panel assembly from the control box, gently tap the bottom edge of the control panel while lifting panel upwards off hinges.
6. Reverse procedure for reinstalling the control panel assembly.
7. Reestablish power to the dryer.

N. To Replace Dual Control Microprocessor (DMC) Computer

1. Discontinue power to the dryer.
2. Remove the lint drawer and the control door from the dryer. Follow lint drawer, and control and lint door removal procedures in **sections A and B**.
3. Remove screw in the lower right hand corner of the control panel securing panel to control box.
4. Open control panel and disconnect all the harnesses that are connected to the dual microprocessor control (DMC) computer; the two (2) 9-pin wire harness connectors, the 3-pin connector wiring harness coming from the coin acceptor optic switch, and the one (1) 4-pin power wire harness connector.

NOTE: These connectors can be removed from the DMC controller (computer) by squeezing the side tabs while pulling the connector outward.

5. Depending on the service function to be performed, the control panel assembly can be left on the control box or removed entirely from the dryer. To remove the control panel, follow control panel removal procedure, **section 1, step 5**.
6. Disconnect the touch pad (keypad) ribbon connector by holding on to **blue** ribbon connector and pulling outward.
7. Remove the two (2) screws securing the dual microprocessor (DMC) computer to the metal control panel and gently disassemble the dmc controller (computer) from the panel.
8. Install the new dual microprocessor control (DMC) computer by reversing the procedure in **step 7**.

IMPORTANT: When installing the new dual microprocessor control (DMC), make sure that the transformer on the DMC controller (computer) is located at the bottom area of the control panel.

9. Reverse **steps 1 through 6**.

NOTE: When reconnecting the optic switch harness connector, for single coin acceptor models, connect the harness to the lower of the two (2) connectors on the DMC controller (computer).

NOTE: For models with the dual coin option, the lower denomination harness connector (red, green and orange wires) are connected to the lower connector on the DMC controller (computer), and the higher denomination harness (black, green and orange wires) are connected to the higher connector on the DMC controller (computer).

O. To Replace Touchpad (Keypad)

1. Discontinue power to the dryer.
2. Remove the lint drawer and the control door from the dryer. Follow lint drawer, and control and lint door removal procedures in **sections A and B**.
3. Remove screws located in the bottom right hand corner of the control panel.
4. Open the control panel and disconnect touchpad (keypad) ribbon connector from the DMC controller (computer) by holding on to the blue ribbon connector and pulling outward.
5. Remove the "U" shaped coin reject and return holder located on the bottom of the touchpad (keypad) by removing the two (2) HEX nuts (with a 1/4" nut driver) at the back side of the control panel securing the "U" coin reject and return holder to the panel.
6. Peel the touchpad (keypad) off the panel. The ribbon cable and connector will come out through the slot in the control panel.
7. To replace the touchpad (keypad), peel the paper backing off the new touchpad. Put the ribbon cable and connector through the slot in the control panel. Holding the new touchpad close to the panel, align it into position and gently press into place.
8. Replace the "U" shaped coin reject and return holder removed in **step 5**.
9. Reverse **steps 1 through 4**.

P. To Replace Coin Acceptor

1. Discontinue power to the dryer.
2. Remove the lint drawer and the control door from the dryer. Follow lint drawer, and control and lint door removal procedures in **sections A and B**.

3. Remove screw located in the bottom right hand corner of the control panel.
4. Disconnect the optic switch connector from the jumper connector. This is done by squeezing the optic switch connector tabs and pulling apart.
5. Remove the two (2) nuts holding the "U" shaped coin reject and return holder by using a 1/4" nut driver.
6. Remove the two (2) nuts located at the top of the coin acceptor with the same 1/4" nut driver. The coin acceptor can now be removed.
7. Reverse procedure for installing the new coin acceptor.
8. Reestablish power to the dryer.

Q. To Replace either Motor Relay

1. Discontinue power to the dryer.
2. Remove the lint drawer, and the control door from the dryer. Follow lint drawer, and control and lint door removal procedures in **sections A and B**.
3. Remove screw located in the bottom right hand corner of the control panel and open the panel.
4. Either relay can be removed with the control box in place on the dryer, or the control box can be removed from the dryer and placed on a flat surface. To remove the control box follow control box removal procedure in **section D**.
5. Disconnect the wires on the particular relay that needs to be replaced. Note the location of each wire on the relay.
6. Remove the motor relay from the control box by removing the two (2) screws and nuts securing it to the control box.
7. Replace new relay by reversing the steps above.

NOTE: Be sure to note the location of wires on the relay before removal.

R. Basket (Tumbler) Alignment - Vertical

1. Discontinue power to the dryer.
2. Remove the upper half of the rear split back guard panel to either the top or the bottom basket (tumbler), depending on which basket (tumbler) is being serviced.
3. Loosen the four (4) HEX head bolts in the sides of the bearing box (two [2] on each side).
4. Back off jam nuts on the two (2) Allen head adjustment screws.
5. Turn the screws clockwise evenly to raise the basket (tumbler) or counterclockwise evenly to the lower basket (tumbler).
6. Rotate the basket (tumbler) from the front and check alignment with the main door opening.

IMPORTANT: Leave larger gap from the inside ring on the top of the front panel opening to the basket (tumbler), and a smaller gap on the bottom to compensate for the weight of the clothes being dried.

7. Tighten the four (4) HEX head bolts on the sides of the bearing box, and the two (2) jams (hex) nuts on the Allen head adjustment screws.

8. Check belt tension and make the necessary adjustments. Follow belt and idler tension adjustments procedure in **section K**.
9. Reinstall the upper half of the rear split back guard panel removed in **step 2**.
10. Reestablish power to the dryer.

S. Basket (Tumbler) Alignment - Lateral

1. Discontinue power to the dryer.
2. Remove the upper half of the rear split guard panel to either the top or the bottom basket (tumbler), depending on which basket (tumbler) is being serviced.
3. Loosen the two (2) HEX head bolts (one (1) turn is enough) that hold the pillow block bearing to the bearing box.
4. Back off the two (2) jam (HEX) nuts on the side adjustment bolts. Rotate the basket (tumbler) from the front of the dryer, checking the space between the basket (tumbler) and the front panel. Door opening should be equal on each side.
5. The lateral adjustment (see illustration on page 17):
 - A. To increase gap R, loosen (turn **counterclockwise**) adjustment bolt A and tighten (turn **clockwise**) adjustment bolt B.
 - B. To decrease gap R, loosen (turn **counterclockwise**) adjustment bolt A and tighten (turn **clockwise**) adjustment bolt B.
 - C. To increase gap L, loosen (turn **counterclockwise**) adjustment bolt A and tighten (turn **clockwise**) adjustment bolt B.
 - D. To decrease gap L, loosen (turn **counterclockwise**) adjustment bolt A and tighten (turn **clockwise**) adjustment bolt B.
6. Tighten and secure both adjustment bolts and jam.
7. Tighten bearing bolts loosened in **step 3**.
8. Check belt tension and make the necessary adjustments. Follow belt and idler tension adjustment procedure in **section K**.
9. Reinstall the upper half of the rear split back guard panel removed in **step 2**.
10. Reestablish power to the dryer.

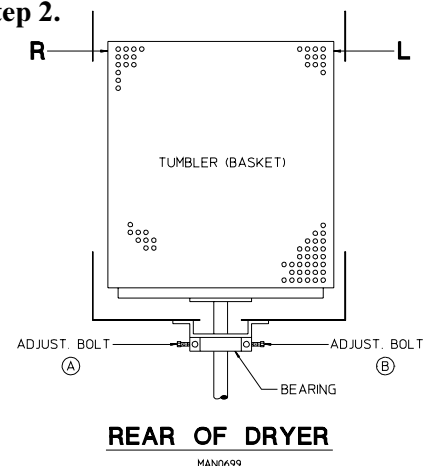

T. To Replace Basket (tumbler) or Basket (tumbler) Support

1. Discontinue power to the dryer.
2. Remove the lint drawer, and the control and lint door from the dryer. Follow lint drawer, and the control and lint door removal procedures in **section A and B**.
3. If lower basket (tumbler) is being serviced, proceed to **step 4** slide the control box out three quarters of the way and disconnect the three (3) wire harness connectors located at the back of the control box, then remove control box from the dryer.
4. Remove front panel from the basket (tumbler) being serviced. Follow front panel removal procedure in **section E**.
5. Remove belt from dryer. Follow belt removal procedure in **section H**.
6. Remove both (upper and lower) halves of the rear split back guard panels to either the top or bottom basket (tumbler), depending on which basket is being serviced.

LOCTITE®

LOCTITE® is being used on **ALL** small dryers (AD-15 through AD-81 including stack dryers) that are manufactured by ADC. LOCTITE® is being applied to **ALL** bearing set screws, used on **ALL** basket (tumbler) shafts, **ALL** idler shafts, **ALL** impellor (fan/blower) shafts, and **ALL** drive shaft bearings.

IMPORTANT
LOCTITE® ADHESIVE HAS BEEN USED
TO SECURE SET SCREWS AND BEARINGS
IN PLACE, ONCE SET SCREWS HAVE BEEN
REMOVED, A GEAR PULLER MAY BE NECESSARY
TO REMOVE BEARING TO AVOID DAMAGE.

P/N 112801

One (1) of these labels is attached to each Basket (tumbler) Bearing Assembly (pillow block bearing box). On the ADG-630 dryer this label is affixed near the small Impellor (fan) Shaft Bearing.

Should readjustments or removal of set screws become necessary in the field and the process becomes difficult, apply heat to the set screw with a soldering gun (450° F) for a few minutes.

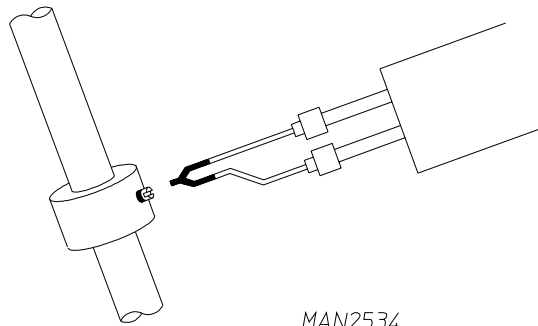

IMPORTANT: Readjustment and removal of the Impellor (fan) Shaft bearings using Green LOCTITE® (#609) require that the bearing itself be heated.
In lieu of heating, ADC recommends the replacement of these assemblies in order to provide a true fit and avoid any warpage upon reinstallation.

NOTE: The application of LOCTITE® during the dryer manufacturing process *does not preclude the recommended six (6) month interval that ADC advises for periodically checking ALL set screws within the dryer.*

7. Loosen the two (2) set screws on the pillow block bearing and flange bearing. The two (2) set screws on the flange bearing can be reached through the opening at the bottom of the bearing box.
8. Remove the basket (tumbler) and support assembly from the front of the dryer. If the basket (tumbler) cannot be removed freely, clean shaft area (with emery cloth) and spray with WD-40 or a similar lubricant. Then, with a block of wood against the shaft end, strike the block of wood with a hammer or mallet to move shaft past any burs made by the set screw.

IMPORTANT: Never strike the shaft directly with a hammer.

9. If entire basket (tumbler) and support assembly is being replaced proceed to **step 11**.
10. Removal of support from the basket (tumbler).
 - A. Remove the socket set screw at center of inside basket (tumbler) back wall.
 - B. Loosen and remove the three (3) sets of nuts and washers from the basket (tumbler) tie rods, then remove the three (3) tie rods.
 - C. Reassemble support to basket (tumbler) reversing the procedure.
11. Reassemble the basket (tumbler) and support assembly into the dryer by reversing **steps 7 and 8**.
12. Reinstall belt removed in **step 5**.
13. Reinstall the front panel removed in **step 4**.
14. Make the necessary vertical alignment and lateral alignment adjustments. Follow basket (tumbler) vertical alignment and basket (tumbler) lateral alignment procedures in **section R and S**.
15. Reinstall both (upper and lower) halves of the rear split back guard panels removed in **step 6**.
16. Make the necessary belt and idler adjustment. Follow belt and idler tension adjustment in **section M**.
17. Reverse **steps 1 through 3**.

U. To Replace Basket (tumbler) Support Pillow Block Bearing

LOCTITE ®

LOCTITE® is being used on **ALL** small dryers (AD-15 through AD-81 including stack dryers) that are manufactured by **ADC**. LOCTITE® is being applied to **ALL** bearing set screws, used on **ALL** basket (tumbler) shafts, **ALL** idler shafts, **ALL** impellor (fan and blower) shafts, and **ALL** drive shaft bearings.

IMPORTANT
 LOCTITE® ADHESIVE HAS BEEN USED
 TO SECURE SET SCREWS AND BEARINGS
 IN PLACE, ONCE SET SCREWS HAVE BEEN
 REMOVED, A GEAR PULLER MAY BE NECESSARY
 TO REMOVE BEARING TO AVOID DAMAGE.

P/N 112801

One (1) of these labels is attached to each basket (tumbler) bearing assembly (pillow block bearing box). On the ADG-630 dryer this label is affixed near the small Impellor (fan) shaft bearing.

Should readjustments or removal of set screws become necessary in the field and the process becomes difficult, apply heat to the set screw with a soldering gun (450° F) for a few minutes.

IMPORTANT: Readjustment and removal of the Impellor (fan) Shaft bearings using Green LOCTITE® (#609) require that the bearing itself be heated.
In lieu of heating, ADC recommends the replacement of these assemblies in order to provide a true fit and avoid any warpage upon reinstallation.

NOTE: The application of LOCTITE® during the dryer manufacturing process *does not* preclude the recommended six (6) month interval that ADC advises for periodically checking ALL set screws within the dryer.

1. Discontinue power to the dryer.
2. Remove the upper half of the rear split back guard panel to either the top or bottom basket (tumbler), depending on which basket (tumbler) is being serviced.
3. Loosen pillow block bearing adjustment jam (hex) nuts and bolts (one [1] on each side of the bearing support).
4. Loosen the two (2) bearing set screws.
5. Remove the two (2) sets of nuts, washers and bolts securing the bearing to the bearing box support, then remove the bearing.
6. Reinstall bearing and hardware by reversing **steps 3 and 5**.
7. Make necessary vertical alignment and lateral alignment adjustments. Follow basket (tumbler) vertical alignment and basket (tumbler) lateral alignment procedures in **sections R and S**.

IMPORTANT: Make sure proper belt adjustment is made.

8. Reinstall the upper half of the rear split back guard panel removed in **step 2**.
9. Reestablish power to the dryer.

LOCTITE ®

LOCTITE® is being used on **ALL** small dryers (AD-15 through AD-81 including stack dryers) that are manufactured by **ADC**. LOCTITE® is being applied to **ALL** bearing set screws, used on **ALL** basket (tumbler) shafts, **ALL** idler shafts, **ALL** impellor (fan/blower) shafts, and **ALL** drive shaft bearings.

IMPORTANT
LOCTITE® ADHESIVE HAS BEEN USED
TO SECURE SET SCREWS AND BEARINGS
IN PLACE, ONCE SET SCREWS HAVE BEEN
REMOVED, A GEAR PULLER MAY BE NECESSARY
TO REMOVE BEARING TO AVOID DAMAGE.
P/N 112801

One (1) of these labels is attached to each Basket (tumbler) Bearing Assembly (pillow block bearing box). On the ADG-630 dryer this label is affixed near the small Impellor (fan) Shaft Bearing.

Should readjustments or removal of set screws become necessary in the field and the process becomes difficult, apply heat to the set screw with a soldering gun (450° F) for a few minutes.

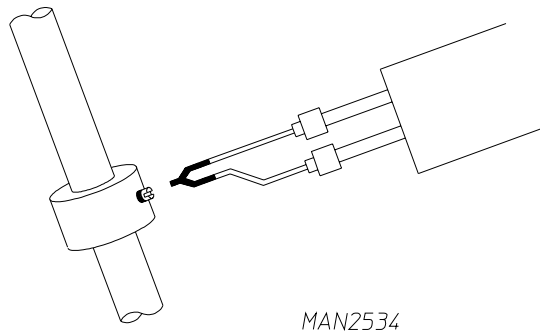

V. To Replace Basket (Tumbler) Support Flange Bearing

IMPORTANT: Readjustment and removal of the Impellor (fan) Shaft bearings using Green LOCTITE® (#609) require that the bearing itself be heated.
In lieu of heating, ADC recommends the replacement of these assemblies in order to provide a true fit and avoid any warpage upon reinstallation.

NOTE: The application of LOCTITE® during the dryer manufacturing process *does not* preclude the recommended six (6) month interval that ADC advises for periodically checking **ALL** set screws within the dryer.

1. Discontinue power to the dryer.
2. Remove the lint drawer, and the control and lint drawer. Follow lint drawer, and control and lint door removal procedures in **section A and B**.
3. If the lower basket (tumbler) is being serviced, proceed to **step 4**. Slide the control box out three quarters of the way and disconnect the three (3) wire harness connectors located at the back of the control box. Then remove the control box from the dryer.
4. Remove front panel from the basket (tumbler) being serviced. Follow front panel removal procedure in **section E**.
5. Remove belt from dryer. Follow removal procedure in **section H**.
6. Remove the upper half of the rear split back guard panel to either the top or the bottom basket (tumbler), depending on which basket (tumbler) is being serviced.
7. Loosen the two (2) set screws in the pillow block bearing and flange bearing. The two (2) set screws on the flange bearing can be reached through the opening at the bottom of the bearing box.
8. Remove the basket (tumbler) and support assembly from the front of the dryer. If the basket (tumbler) cannot be removed freely, clean shaft area (with emery cloth) and spray with WD-40 or a similar lubricant. Use a hammer or mallet to move shaft past any burs made by the set screw.

IMPORTANT: Never strike the shaft directly with a hammer.

9. Remove four (4) sets of nuts, washers and bolts securing the bearing box assembly to the dryer. Then, remove the bearing box assembly.
10. Remove four (4) securing the flange bearing to the dryer, then remove the bearing from the dryer. Reverse procedure for installing new bearing.
11. Reassemble basket (tumbler) and support assembly into the dryer.
12. Reassemble bearing box assembly to dryer.
13. Reconnect belt to idler and motor removed in **step 5**.
14. Reinstall the front removed in **step 4**.
15. Make the necessary vertical alignment and lateral alignment adjustments. Follow basket (tumbler) vertical alignment and basket (tumbler) lateral alignment procedures in **sections R and S**.
16. Check belt tension and make the necessary adjustments. Follow belt and idler tension adjustment procedures in **section K**.

W. To Replace 330° F (Burner) Hi-Limit Switch (Thermostat)

NOTE: The 330° F (burner) hi-limit switch (thermostat) is located on the burner chamber at the rear of the dryer.

1. Discontinue power to the dryer.
2. Remove the lower half of the split back guard panel to either the top or the bottom basket (tumbler) is being serviced.
3. Disconnect wiring to the 330° F (burner) hi-limit (thermostat).
4. Disassemble hi-limit from burner chamber by removing the two (2) sheet metal screws securing hi-limit to the burner box chamber.

X. To Replace Sail Switch

NOTE: The sail switch and damper is located in the gas valve train assembly.

1. Discontinue power to the dryer.
2. Remove the lint drawer, and the control and lint door. Follow lint drawer, and control and lint door removal procedures in **section II, A and B.**
3. Remove sail switch and damper rod assembly from the dryer.
4. Disassemble sail switch bracket assembly from the dryer by removing the two (2) phillips head screws located in the lint drawer area.
5. Disassemble sail switch bracket assembly from the dryer by removing the two (2) slotted head machine screws securing the sail switch to the sail switch bracket.

NOTE: When disassembling the sail switch from the bracket, hold on to the twin speed nut located at the back side of the sail switch bracket into which the screws are threaded.

6. Disconnect the two (2) wires from the sail switch.
7. Reverse steps 3 through 6 for installing new sail switch.
8. Adjust the sail switch by bedding the actuator arm of the switch itself so that when the sail switch damper is manually closed the sail switch activates and when the damper is released the sail switch deactivates.
9. Reverse steps 1 and 2.

Y. To Replace Main Door Switch

1. Discontinue power to the dryer.
2. Open the main door completely.
3. Remove the two (2) phillips head screws holding the main door switch housing in place.
4. Disconnect the main door switch wires from switch, two (2) yellow wires.
5. Disassemble door switch by removing the two (2) nuts and washers holding the door switch in place.
6. Reverse this procedure for installing new door switch.

IMPORTANT: Under no circumstances should the door switch be disabled.

IMPORTANT: When reinstalling the door switch housing to the dryer, be sure the internal wires **do not** get pinched between the door switch housing and the front panel.

7. Reestablish power to the dryer.

Z. To Replace Direct Spark Ignition (DSI) Module

1. Remove the lint drawer, the control and lint door, and the gas valve train assembly from dryer. Follow gas valve train removal procedure in **section C.**
2. Disassemble DSI module and bracket assembly from the gas valve train slide by removing the two (2) sets of nuts and washers securing the bracket to the gas valve train.
3. Disconnect all wiring to the DSI module including the orange high voltage (HV) lead.

IMPORTANT: Identify location of each wire for correct reinstallation.

4. Disassemble DSI module from the bracket by removing the four (4) sets of nuts and washers securing the DSI module to the bracket.
5. Reverse **steps 3 through 5** for installing the new DSI module.

IMPORTANT: Do be sure wires removed in **step 4** are connected to the correct terminal positions. When connecting the orange high voltage (HV) lead to the DSI module, be sure it is securely in place.

6. Reinstall the gas valve train, the control and lint door and the lint drawer.
7. Reestablish power to the dryer.

AA. To Replace Ignitor and Probe

1. Discontinue power to the dryer.
2. Remove the lint drawer, the control and lint door and the gas valve train assembly from dryer. Follow gas valve train removal procedures in **section C**.
3. To replace either ignitor probe or flame sensor simply remove phillips head screw holding device to bracket and disconnect wire.
4. Reverse **steps 2 and 3** for installing the new ignitor or flame probe assembly.
5. Reestablish power to the dryer.

BB. To Replace Gas Valve

1. Discontinue power to the dryer.
2. Close all gas shut-off valves in gas supply line to the dryer.
3. Remove the lint drawer, the control and lint door, and the gas valve train assembly from dryer. Follow Gas valve removal procedure in **section C**.
 - A. Remove the two (2) sheet metal screws from bottom side of the gas valve train slide which secure the brackets at the inlet side of the gas valve.
 - B. Remove the two (2) sets of nuts securing the manifold bracket to the gas valve train slide and disassemble valve and manifold assembly from slide.
4. Remove 1/2" street elbow from inlet side of the gas valve.
5. Remove manifold from gas valve.
6. Remove pressure test line (brass) elbow from the gas valve pressure tap.
7. Reverse **steps 4 through 6** for installing the new gas valve.

IMPORTANT: When using pipe dope for gas connections, only use pipe dope suitable for both natural gas and L.P. gas applications.

NOTE: The new gas valve is supplied with a plug at the pressure tap. Remove this plug and replace it with the brass elbow removed in **step 6**.

8. Reassemble the gas valve and manifold assembly to the gas valve train slide by reversing **step 3**.
9. Reinstall the gas valve train assembly into the dryer removed in **step 3**.

NOTE: Be sure the union shut-off valve at the inlet area of the gas valve is in the "on" (open) position.

10. Reinstall the control and lint door, and the lint drawer removed in **step 3**.
11. Open all shut-off valves closed in **step 2**.
12. Reestablish power to the dryer.

CC. To Convert Dryer from Natural Gas to Liquid Propane (L.P.) Gas

1. Discontinue power to the dryer.
2. Close all gas shut-off valves in the gas supply line to the dryer.

3. Remove the lint drawer, the control and lint door, and the gas valve train assembly from the dryer. Follow gas valve train removal procedure in **section C**.
4. With the gas valve train assembly removed from the dryer, remove the two (2) sets of nuts securing the manifold bracket to the gas valve train slide.
5. Pull manifold and valve assembly back slightly so that the burner orifice is exposed.
6. Unscrew burner orifice and replace with L.P. orifice.

IMPORTANT: Use extreme care when removing and replacing orifice. This orifice is made of brass and is easily damaged.

NOTE: Consult factory when replacing orifice for elevations over 2,000 feet.

7. Reinstall the valve and manifold assembly by reversing **steps 4 through 6**.
8. Locate valve regulator adjustment cover. Remove cover with slotted screwdriver, install valve L.P. stem and spring kit, then reinstall cover.
9. Reinstall the gas valve train assembly removed in **step 3**.

IMPORTANT: Use extreme care when removing and replacing the orifice. This orifice is made of brass and is easily damaged.

10. Reinstall the control and lint door and the lint drawer removed in **step 3**.
11. Convert opposite basket by following **steps 2 through 11**.
12. Once the conversion of both baskets is complete, open all gas shut-off closed in **step 2**.

IMPORTANT: The gas valve pressure regulations are now blocked open. Gas pressure must now be regulated at the source (L.P. tank) or a regulator must be added in the gas supply line of each dryer. A consistent pressure of 10.5 to 11 inches must be provided.

13. Reestablish power to the dryer.

DD. To Replace Coin Vault

1. Discontinue power to the dryer.
2. Remove both (upper and lower) lint drawers and the control and lint doors from the dryer. Follow lint drawer, and control and lint doors from the dryer. Follow lint and control and lint removal procedures in **sections A and B**.
3. Remove the control box and the lower front panel from the dryer. Follow front panel removal procedures in **section E**.
4. Remove the coin box.
5. From inside of coin vault, loosen and remove the four (4) nuts securing the coin vault to the dryer inner top, then the coin vault from the dryer.
6. Install the new coin vault by reversing **step 5**. Do not tighten the four (4) nuts. They must be left loose at this time for the coin vault adjustment.
7. Reinstall the front panel removed in **step 3**.
8. Tighten the four (4) coin vault HEX nuts left loosen in **step 6**.
9. Reinstall the coin box removed in **step 4**.
10. Reinstall the control box removed in **step 3**.
11. Reinstall control and lint doors, and lint drawers removed in **step 2**.

12. Reestablish power to the dryer.

EE. To Remove Main Door

1. Open main door completely.
2. While holding the door in place, remove the four (4) phillips head screws securing the main door to the front panel hinge.
3. Reinstall the main door by reversing procedure.

FF. To Install New Main Door Glass

1. Remove the main door assembly from the dryer. Follow main door removal procedure in **section DD** above.
2. Lay main door on flat surface with front of door face down.
3. Apply a narrow bead of silicone, ADC P/N 170730, all around the main door area where the glass will rest.

IMPORTANT: This area must be completely cleaned for correct bonding.

4. Install the glass onto the door glass adhesive and slightly press glass in place.

IMPORTANT: Do not press hard or silicone thickness between the glass and the door will be reduced resulting in poor bonding.

5. The door assembly should now be put in an area where it will not be disturbed for at least 24 hours. Depending on the conditions, the curing time of this adhesive is 24 to 36 hours.
6. After the 24 to 36 hour curing period, reinstall main door on the dryer.

GG. To Replace Main Door Gasket

1. Open main door completely.
2. Remove all existing main door gasket material with a putty knife or similar device. Make sure door surface is as clean as possible.
3. Apply a small bead of adhesive, ADC P/N 170730, around the main door gasket cavity area.
4. Gently push gasket in place starting at the left side of the door, near the main door switch.
5. Dryer should be left out of operation for at least 8 hours.

HH. To Replace Main Door Hinge

1. Discontinue power to the dryer.
2. Remove the lint drawer, the control and lint door, the control box and the front panel from the dryer. Follow control box removal procedure in **section E**.

NOTE: Before removing the front panel from the dryer, remove the main door assembly. Follow main door procedure in **section EE**.

3. Remove main door switch housing from the front panel. Follow main door switch replacement procedure in **section X**.
4. Disassemble main door hinge from the front panel by removing the four (4) nuts securing hinge to back side of front panel.
5. Position the new hinge so that the part of the hinge that the main door is secured to is towards the front panel main door opening.
6. Install hinge studs through the front panel holes and secure in places with the four (4) nuts removed in **step 4**.
7. Reinstall main switch housing removed in **step 3**.
8. Reverse **steps 1 and 2**.

SECTION III

TROUBLESHOOTING

The information provided is a quick reference to help isolate the most probable components associated with the difficulty described. The experienced technician realizes, however, that a loose connection or broken or shorted wire may be at fault where electrical components are concerned. . . not necessarily the suspect component itself. Electrical parts **should always be** checked for failure before being returned to the factory.

The information provided should not be misconstrued as a handbook for use by an untrained person in making repairs.

IMPORTANT: When replacing blown fuses, the replacement must be of the exact rating as the fuse being replaced.

WARNING: All service and troubleshooting **should be** performed by a qualified professional.

WARNING: While making repairs, observe all safety precautions displayed on the dryer or specified in this manual.

A. No L.E.D. Display

1. Service panel fuse blown or tripped breaker.
2. Blown control circuit fuse (3AG 1/2-Amp [Slo Blo] Fuse).
3. Failed Dual Microprocessor Control (DMC) computer.

B. Basket (tumbler) motor does not start, DMC computer shows drying cycle in progress and L.E.D. motor indicator dot is on

1. Dual Microprocessor Control (DMC) computer indicator is on
 - a. Failed motor contractor or relay.
 - b. Failed motor.
2. Dual Microprocessor Control (DMC) computer indicator is off (and L.E.D. display does not read "door")
 - a. Failed Dual Microprocessor Control (DMC) computer.
3. Loose tumbler and basket belt (check tension and adjustment).
4. Tumbler and basket belt jumped off of motor or idler shaft.
5. Broken tumbler and basket belt.

C. The dryer will not stop, even with no cycle (L.E.D. reads "FILL") in progress

1. Failed motor contractor or relay.

D. The dryer operates for a few minutes, and with the DMC computer motor L.E.D. indicator dot on the motor stops, and ten after a period of time restarts on it's own

1. Motor is overheating and tripping out on its' internal overload

- a. Motor air vents clogged with lint.
- b. Low voltage to motor.

E. The dryer operates for a few minutes and then stops, DMC computer L.E.D. continues to read cycle in progress, indicator dots are off and dryer can be restarted by pressing selection key

- 1. Intermittent connection in main door and lint drawer circuit
 - a. Main door switch or lint drawer switch out of proper adjustment.
 - b. Loose connection in main door switch or lint drawer switch wiring.
 - c. Failed main door switch or lint drawer switch.

F. The dryer does not start, and the DMC computer L.E.D. display reads "door"

- 1. Dual Microprocessor Control (DMC) "door" input L.E.D. is off
 - a. Main door or lint drawer is not properly closed.
 - b. Failed main door switch.
 - c. Failed lint drawer switch.
 - d. Open circuit (broken wire or termination) in main door switch circuit wiring or lint drawer switch circuit wiring.
 - e. Failed 24 VAC step down transformer.
- 2. Dual Microprocessor Control (DMC) "door" input L.E.D. is on
 - a. Failed Dual Microprocessor Control (DMC) computer.

G. The dryer does not start (COIN MODELS ONLY) coins inserted and the L.E.D. continues to read "FILL" or "Amount to Start" (does not read "PUSH")

- 1. Coin acceptor is not adjusted properly (housing is not flush with panel) or is dirty with lint.
- 2. Failed coin acceptor optic switch.
- 3. Parameter in Program Location 01 (PL01) set incorrectly.
 - a. Bad coin program should be set for "bCrS" and not "bCLO".

H. DMC computer L.E.D. display reads "dSFL"

- 1. L.E.D. display consistently reads "dSFL" and will not clear
 - a. Dual Microprocessor Control (DMC) computer 1/8-Amp fuse is blown.
 - b. Failed Dual Microprocessor Control (DMC) computer temperature sensor.
 - c. Broken wire or termination in sensor harness somewhere between the sensor bracket and the Dual Microprocessor Control (DMC) computer.
- 2. L.E.D. display reads "dSFL" for a short period of time (30 seconds or less) and then returns to the normal stop "FILL" mode.

NOTE: Once the Dual Microprocessor Control (DMC) computer detects a problem, it updates every 30 seconds so that if a problem was a loose connection in this circuit which corrected itself, the "dSFL" display condition would automatically be cancelled.

- a. Loose wire or termination in sensor harness somewhere between the sensor bracket and the Dual Microprocessor Control (DMC) computer.
- b. Failed Dual Microprocessor Control (DMC) computer temperature sensor.

I. DMC computer L.E.D. display reads "Hot"

The "Hot" display condition indicates a possible overheating condition. The Dual Microprocessor Control (DMC) computer monitors the temperature in the dryer at all times. If the DMC computer detects that the temperature in the dryer has exceeded 170° F (77° C), it will disable **ALL** of the dryer outputs (shut the dryer down), the buzzer (tone) will sound for approximately 5 seconds, and the L.E.D. display will continue to read "Hot" until the temperature has dropped to 170° F (77° C) or lower and the DMC computer is manually reset by closing and opening the Program Switch (PS).

Possible reasons for overheating

1. Restriction in location exhaust duct work.
 - a. Dryer exhaust damper stuck in closed position.
 - b. Undersized exhaust duct work.
2. Insufficient makeup air.

J. DMC computer L.E.D. display reads "SEFL"

The "SEFL" display condition indicates a rotational sensor circuit failure which means there is a fault somewhere in the basket (tumbler) rotation detection circuit or the Dual Microprocessor Control (DMC) computer program related to this circuit (PL01) is set incorrectly in the active mode (SEn) with the optional rotation sensor and **should be** set in the nonactive mode ("nSEn").

If the dryer is equipped with the optional rotational sensor and for whatever reason the Dual Microprocessor Control (DMC) computer detects that the basket (tumbler) is not turning, it will disable **ALL** of the dryer outputs (shut the dryer down) and the L.E.D. will read "SEFL". The L.E.D. display will continue to read "SEFL" until the Dual Microprocessor Control (DMC) computer is manually reset by closing and opening the Program Switch (PS).

Possible causes

1. Loose or slipping (out of proper adjustment) basket or tumbler belt.
2. Broken basket or tumbler belt.
3. Failed motor.
4. Failure in the rotational sensor circuit
 - a. Failed rotational sensor.
 - b. Loose connection or break between the rotation sensor and the Dual Microprocessor Control (DMC) computer.

K. DMC computer will only accept certain keyboard (touchpad) entries

1. Failed Keyboard (touchpad) label assembly.
2. Failed Dual Control (DMC) computer.

L. DMC computer locks up and the L.E.D. display reads erroneous messages or only partial segments

1. Transient power voltage (spikes), disconnect power to the dryer, wait one (1) minute (**NOTE:** for dryer models with the optional battery back up, disconnect battery), then reestablish power to the dryer. If the problem is still evident, proceed to **Items M2 through M4.**
2. Failed keyboard (touchpad) label assembly
3. Improper grounding of the dryer or the Dual Microprocessor Control (DMC) computer ground connections to the panel or the dryer are not proper.
4. Failed Dual Microprocessor Control (DMC) computer.

M. Dryer stops during a cycle and the DMC computer L.E.D. display returns to "FILL"

If dryer is equipped with optional battery back up

1. Refer to **Item M1, Item M3, or Item M4** above.

If dryer does not have optional battery back up:

1. Loose connection somewhere in the power source to the dryer.
2. Loose connection in main power circuit to the Dual Microprocessor Control (DMC) computer.
3. Improper grounding of the dryer or the Dual Microprocessor Control (DMC) computer ground connections to the panel or the dryer are not proper.
4. Failed Dual Microprocessor Control (DMC) computer.

N. Heating unit is not operating (no heat) basket (tumbler) is turning, DMC computer heat indicator dot is on but "HEAT" output L.E.D. is not

1. Failed Dual Microprocessor Control (DMC) computer.

O. Gas heating unit is not operating (no heat) both DMC computer heat indicator dot and "HEAT" indicator are on but no spark at burner area when the dryer is first started

1. Fault in sail switch circuit
 - a. Sail switch is out of adjustment or has failed.
 - b. Sail switch damper is not closing or is fluttering
 - 1) Lint drawer or screen is dirty or clogged.
 - 2) Restriction in exhaust duct work.
2. Fault in burner hi-limit circuit or thermostat.
3. Fault in basket (tumbler) hi-limit circuit or thermostat.
4. Failed Direct Spark Ignition (DSI) module (burner control).
5. Failed Direct Spark Ignition (DSI) ignitor or flame-probe assembly.

P. No heat (GAS MODELS ONLY) ignitor sparks but there is no flame at burner

1. Direct Spark Ignition (DSI) ignitor probe out of adjustment.
 - a. Reposition ignitor assembly closer to the burner ribbon area. Also check to make sure ribbon burner is flush all around the top of the burner tube (ribbon should not stick up in any area).
 - b. Check gap between ignitor assembly and top of the burner. Gap **must be** set 1/8" +/- 1/32".
2. Failed ignitor flame-probe assembly or problem with wiring connections to the assembly.
3. **NO** gas (check shut off valves) or insufficient (low Water Column [W.C.] pressure)
4. Failed Direct Spark Ignition (DSI) module.
5. Failed gas valve.

Q. No heat (GAS MODELS ONLY) ignitor sparks, burner goes on and off right away

1. DSI flame sensor (probe) out of adjustment. . .reposition closer to the flame area.
2. Failed Direct Spark Ignition (DSI) flame sensor probe.
3. Sail switch is fluttering
 - a. Lint drawer or screen is dirty or clogged.
 - b. Restriction in exhaust duct work.
4. Insufficient makeup air.
5. Failed Direct Spark Ignition (DSI) module.

R. Dryer operates, but is taking to long to dry

1. Exhaust duct work run is too long or is undersized.
2. Low or inconsistent gas pressure.
3. Insufficient makeup air.
4. Poor air and gas mixture at burner, yellow or poor flame pattern. Adjust gas burner air adjustment shutters.
5. Lint drawer or screen not being cleaned out on a regular basis or often enough.
6. Extractors (washers) not performing properly.
7. Sail switch is fluttering, restriction in exhaust (GAS and ELECTRIC MODELS ONLY).
8. Failed Dual Microprocessor Control (DMC) computer temperature sensor, temperature calibration is inaccurate.
9. Failed Dual Microprocessor Control (DMC) computer, temperature calibration is inaccurate
10. Failed burner hi-limit.
11. Failed basket (tumbler) hi-limit thermostat.
12. Lint accumulation in location exhaust system.

S. Condensation on main door glass

1. Too long, undersized or improperly installed duct work.
2. Exhaust back draft damper is stuck closed or partially closed.

3. Restriction in exhaust duct work.

T. Dryer is making scraping noise at basket (tumbler) area

1. Check for objects caught in basket (tumbler) wrapper area.
2. Basket (tumbler) is out proper alignment
 - a. Check gap between the front panel and the basket (tumbler) front set screws may have come loose and basket (tumbler) walked forwards or backwards.
3. Loose or broken basket (tumbler) tie rod.
4. Broken basket (tumbler support).

U. Excessive noise or vibration

1. Dryer is not leveled properly.
2. Impellor (fan) out of balance or broken.
3. Loose basket (tumbler) tie rod.
4. Basket (tumbler) is out of adjustment or adjustment bolts (hardware) are loose.
5. Loose motor or motor mount assembly.

V. Basket (tumbler) turns too fast (as opposed to other baskets [tumblers])

1. Foreign objects caught between basket (tumbler) belt and motor shaft.

W. Computer registers more time than what was inserted (i.e. 99 mins. one coin)

1. Replace optic switch (P/N: 137056)
2. Replace computer board.

SECTION IV

ELECTRICAL TROUBLESHOOTING

NOTE: Diagrams used in the section include: BB72611 and all the revisions (a revision is the letter after the number i.e. BB72611 A, B482611.)

NOTE: A volt and ohm meter is needed for this section.

A. No Display Condition

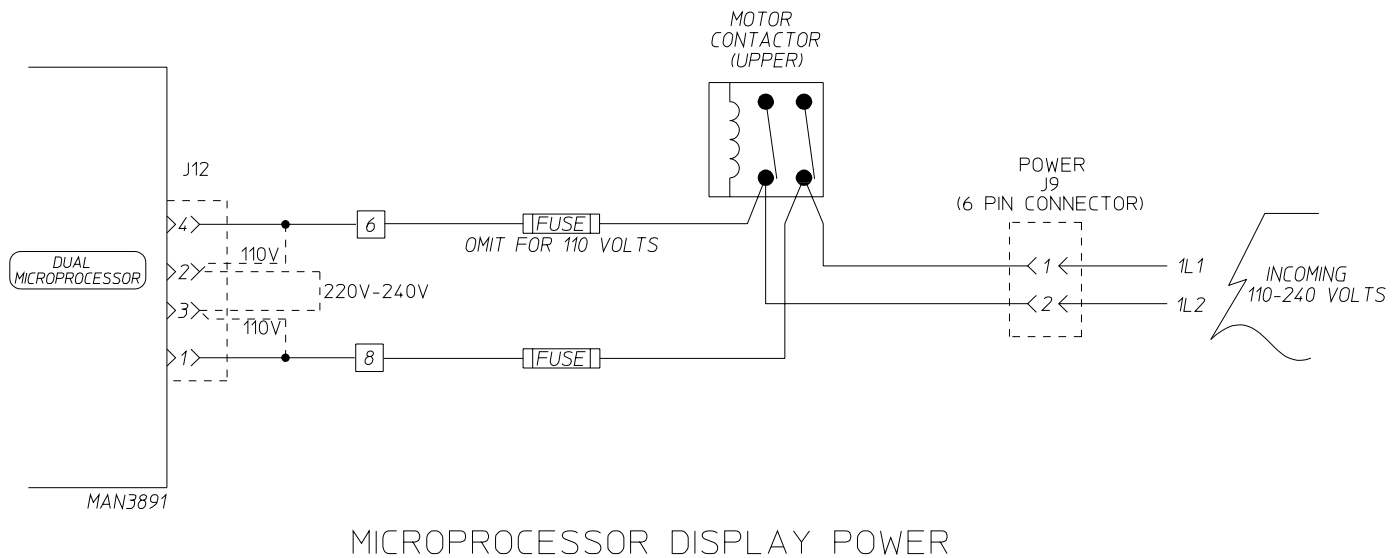

1. Check top pocket circuit breaker panel for this particular dryer. If tripped reset.
2. Check .5 amp fuse located in the control box. If blown replace.
3. Check for voltage (110, 208, 220, 230, 240) across the top motor contactor. This will have two black wires together to one point and two white wires to another point on the contactor. Take a voltage reading across these two points. For 208 volts and higher it will be two black and two red wires.
4. If no voltage, problem is a bad wire or termination between the contactor and the J9 power connector, or from the J9 connector to the incoming voltage. If voltage is present, check for voltage across block numbers 6 and 8.
5. If no voltage, problem is a bad wire or termination between the contactor and the terminal block numbers 6 and 8. If voltage is present, check for voltage across pins 1 and 4 of the computer 4 pin connector (J12).
6. If there is no voltage, the problem is a bad wire or termination between terminal block numbers 6 and 8 and the 4 pin connector (J12). If voltage is present, the problem is a faulty computer

B. No Start Condition (Motor Doesn't Turn)

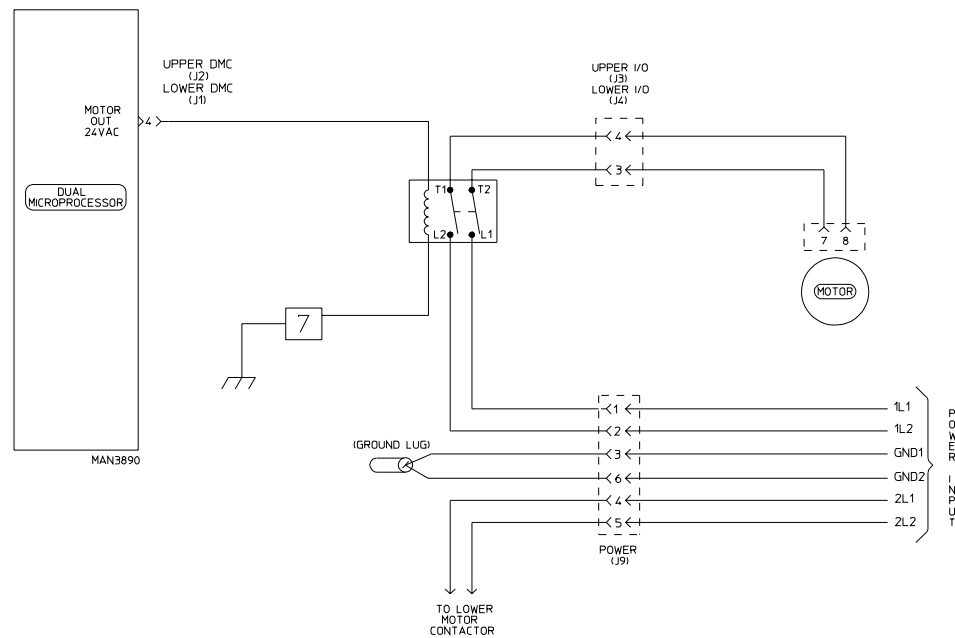

MOTOR SECTION

NOTE: The following sections must be performed with the appropriate L.E.D. and L.E.D. indicator dots on.

NOTE: In the following sections the voltage readings are for 24 VAC otherwise specified.

NOTE: If the L.E.D. indicator dot is on and the appropriate L.E.D. output light is not on, replace computer.

1. Check to see if the appropriate "door" L.E.D. light is on (refer to section 6 of this manual for L.E.D. identification). If light is not on refer to "door" section in the electrical troubleshooting of this manual.
2. Check for voltage across the coil connections of the particular contacting pertaining to the tumbler being your worked on (top contactor-top pocket, bottom contactor-bottom pocket.)

If voltage is evident:

- A) Manually push down the top of the contactor. If motor turns, replace the contactor.
- B) If motor doesn't turn, problem is a bad wire or termination from contactor down to the motor or faulty motor.

NOTE: Make sure high voltage (110 to 240 V) is present across the top half of the contactor.

If voltage is not present:

- A) Check for voltage across the appropriate 9 pin connector, pin # 4 and the "GND" terminal of the computer. If voltage is evident, problem is bad wire or termination on that blue motor output wire (pin #4) to the contactor coil. Problem could also be a bad wire or termination on the green ground wire from the side of the coil to terminal block #7. If no voltage, replace computer.

C. No Heat Condition (Gas)

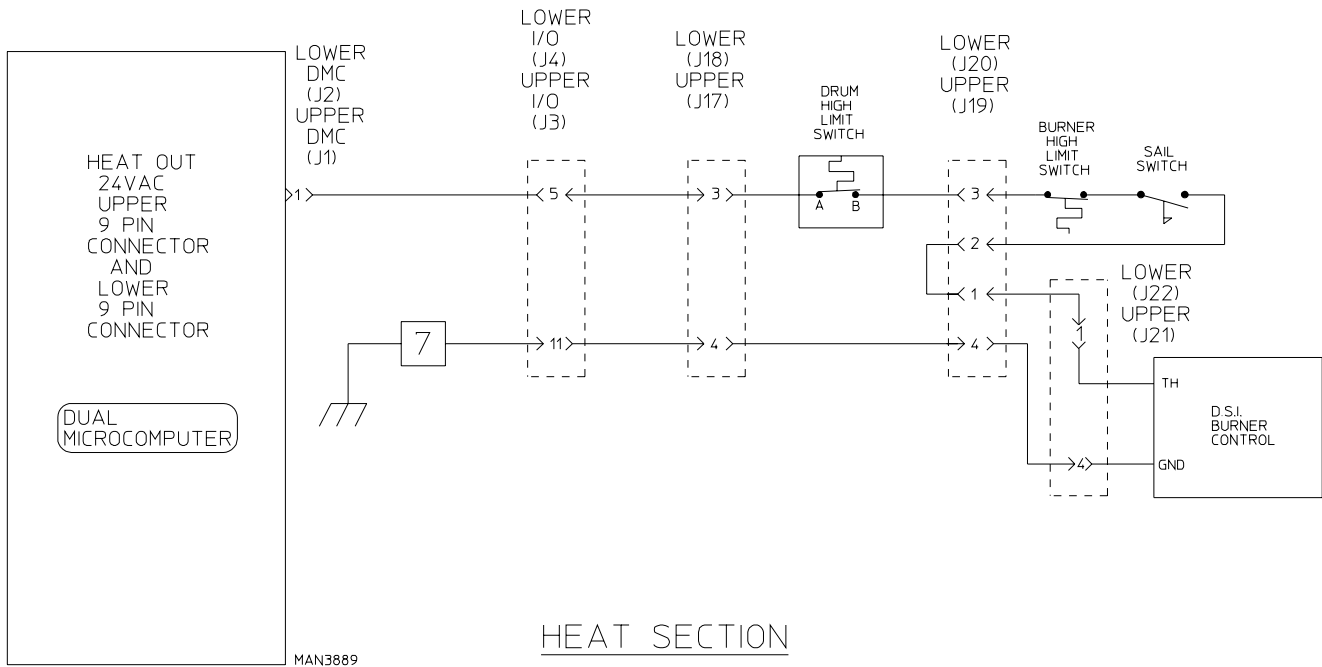

1. Check to see if D.S.I. module fault indicator L.E.D. is red. If red, refer to ADC D.S.I. troubleshooting manual (P/N 450142).
2. Check for voltage across the "TH" and "GND" terminal of the module. If voltage is evident refer to ADC D.S.I. technical manual (P/N 450142).

NOTE: In the preceding steps, when checking the voltage leave one of your meter lead to terminal block #7 or any good ground connection. Make sure sail switch damper is closing properly.

IMPORTANT: By no means should the sail switch be tampered with or bypassed when under normal drying conditions.

3. Check for voltage across both terminals of the sail switch. If voltage is evident on both terminals, check for bad wire or termination on the red wire that leaves the sail switch and passes through the gas valve train connector to the "TH" terminal on D.S.I. module. If voltage is evident on one terminal of the sail switch, replace the sail switch.

4. Check for voltage across both terminal of the burner hi-limit switch.

If voltage is evident on both terminals, check for bad wire or termination on the red wire from the burner hi-limit switch through the J19 connector (top tumbler) or the J20 (bottom tumbler) connector, to the sail switch.

If voltage is evident on one terminal of the burner hi-limit switch, replace this hi-limit switch.

5. Check for voltage across both terminals of the tumbler hi-limit switch. If voltage is evident on both terminals, check for bad wire or termination on the red wire from the tumbler hi-limit switch through the J19 connector (top tumbler) or the J20 (bottom tumbler) connector, to the burner hi-limit switch. If voltage is evident on one terminal replace the tumbler hi-limit switch.

6. Check for the "heat out" voltage of the computer upper DMC connector J1 pin #1 for the top pocket, or the lower DMC connector J2 pin #1. If voltage is evident on the "heat out" pin of the computer, check for bad wire or termination on the red wire from the computer "heat out" which passes through the I/O connector in the back of the computer box, to the tumbler hi-limit switch.
7. If no voltage, replace the computer.

D. "dOOr" Condition

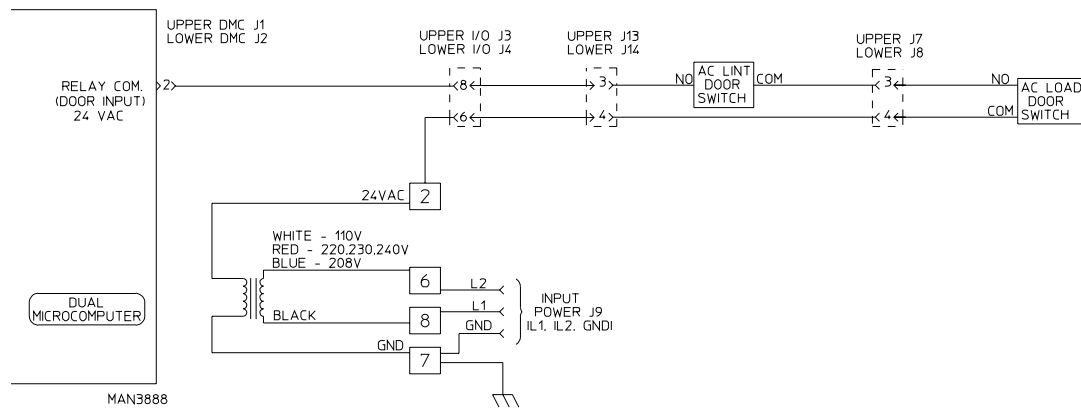

A.C. DOOR SWITCH CIRCUIT

NOTE: The following sections must be performed with the appropriate output L.E.D. and appropriate indicator dots on.

NOTE: In the following sections the voltage you are checking for is 24 VAC unless otherwise specified.

NOTE: If the L.E.D. indicator dot is on and the appropriate L.E.D. output light is not on, replace the computer.

NOTE: If the display reads "dOOr" this indicates that there is an open circuit in the computer's door switch circuit. This fault display involves the door switch, the computer, the transformer, the lint drawer switch or the harness. If the L.E.D. input light on the component side of the computer is on and you are getting the "dOOr" code, replace the computer.

1. Remove the wires from the door switch and check for continuity while pushing down the plunger of the switch. If no continuity, replace door switch. If continuity exists reassemble connections to the switch.
2. Repeat the same process as in step #1 for the lint drawer switch.
3. Check for voltage across terminal block #2 and #7. If no voltage is present, replace the 24 volt transformer.
4. Check for voltage on pin #2 (yellow wire) of the computer 9 pin connector (top 9 pin connector is for the top tumbler and the bottom 9 pin connector is for the bottom tumbler). If voltage is present, replace the computer.

5. If the above steps were performed correctly, the problem could be a bad wire or termination, from the 24 volt transformer through the I/O J4 (top tumbler) or J3 (bottom tumbler) connector, or to the main and lint drawer switches.

E. "dSFL" Condition

When the display reads "dSFL" it is an indication that there is a fault in the microprocessor's heat sensing circuit. This circuit includes the microprocessor controller, the temperature sensor or the wires or connectors leading to and from these two points.

1. Check to see if the 1/8 amp fuse located on the computer is blown. To verify check with an ohm meter. If no continuity replace with P/N 136048 fuse. If fuse repeatedly blows out refer to step 4.
2. Replace the temperature sensor P/N 880111.
3. Discontinue power to the dryer. Disconnect the 9 pin connector from the computer top tumbler (top connector) or bottom tumbler (bottom connector). The temperature sensor is wired to in pins #7 and #8 of the 9 pin connector. Check for continuity on each wire from the 9 pin connector to the temperature sensor connector above the lint screen. If there is no continuity on either one of these two wires, the problem is a bad wire or termination between the computer to the temperature sensor bracket.
4. If the computer fuse repeatedly blows, there is a short in one of the sensor wires.

SECTION V

TECHNICAL INFORMATION

A. Data Label

MODEL AD-630	SERIAL NO. 399865 SY	
MANUFACTURING CODE NUMBER 6305147130317010840XP000000000000		
TYPE OF HEAT GAS/NATURAL	HEAT INPUT 136,000 BTUH	
ELECTRIC SERVICE 115V/60HZ/1PH/3W 12A		
GAS MANIFOLD PRESSURE 3.5 IN WC		
FOR USE WITH NATURAL AND L.P. GASES		
ANS Z215.2	1992	CLOTHES DRYER, VOL.II

112026

MAN4005

When contacting ADC, certain information is required to insure proper service and parts information. This information is on the data label located on the inside of the control door. When contacting ADC, please have the model number and serial number available.

Information on the Data Label

1. MODEL NUMBER - The model number is an ADC number which describes the size of the dryer and the type of heat (gas, electric, or steam).
2. SERIAL NUMBER - The serial number allows ADC to gather information on your particular dryer.
3. MANUFACTURING CODE NUMBER - The manufacturing code number is a number issued by ADC which describes all possible options on your particular model.
4. TYPE OF HEAT - Describes the type of heat: gas (natural or L.P., electric) or steam.
5. HEAT INPUT - (For gas dryers) describes the heat input in British Thermal Units.

6. ELECTRIC SERVICE - Describes the electric service for your particular model.
7. GAS MANIFOLD PRESSURE taken at the gas valve. (see "Using a Manometer")

B. Using a Manometer

HOW TO USE A MANOMETER

1. With dryer in nonoperating mode, remove plug on the gas valve pressure tap.
2. Attach plastic tubing to pressure tap. (Fitting is supplied with manometer. See illustration.)
3. Attach manometer to dryer using magnet.

NOTE: Place manometer in a position so that readings can be taken at eye level.

4. Fill manometer as shown in illustration to the zero level.
5. Start dryer. With burner on, take a reading.
 - a. Read water level at the inner tube. Readings should be taken at eye level.
 - b. Correct readings should be:

NATURAL GAS:

3.5 to 4.0 inches W.C.

L.P. GAS:

10.5 to 11 inches W.C.

6. If water column pressure is incorrect, refer to "TO ADJUST GAS PRESSURE".
7. Reverse procedure for removing manometer.

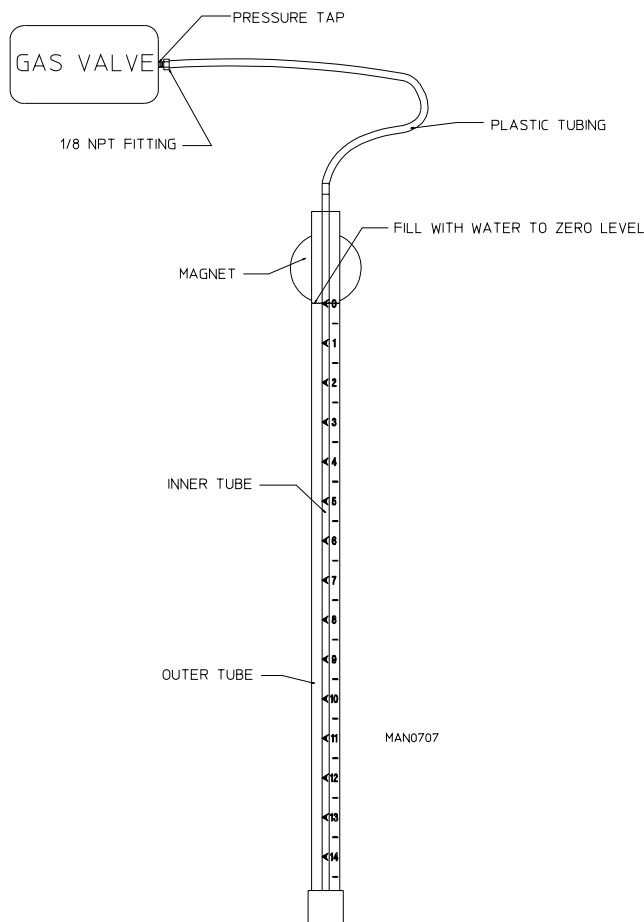

C. L.E.D. Display Codes

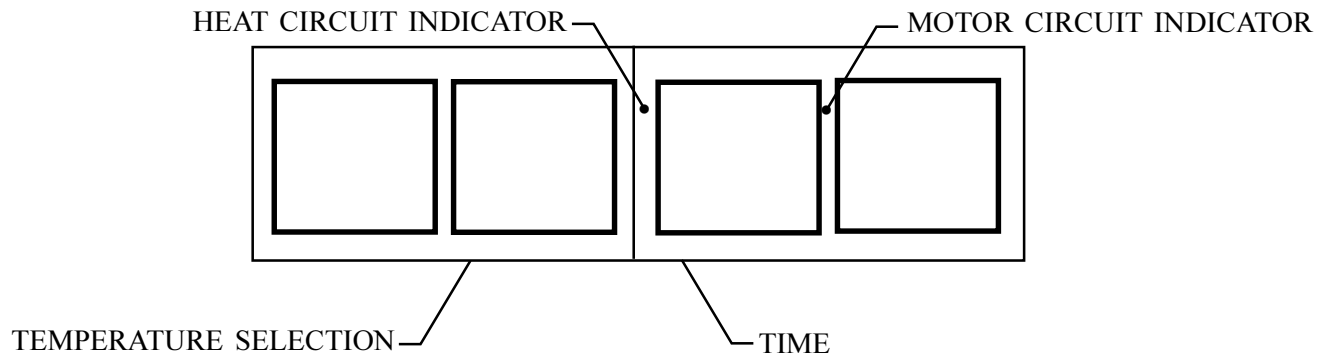

A	
ACOn	Automatic Cycle (Slope Program Factor)
Adrt	Accumulative Coin
AFAt	Maximum Auto Dryness Time
AGt	Amount for Additional Time
ArIn	Active Anti-Wrinkle Guard Time
AtSt	Accumulative Time
AUtO	Amount to Start
b	Automatic Mode (Patent No. 4,827,627)
bCLO	Automatic Cycle (Heat Loss [offset] Factor)
bCrS	Bad Coin Lockout
bUZ	Bad Coin Reset
CEL	Buzzer (Tone)
CLCC	Degree in Celsius
COIn	Clear Left Coin Count
CrCC	Coin Mode
donE	Clear Right Coin Count
	Drying and Cooling Cycles Complete
	or
	Dryer is in Anti-Wrinkle Cycle

door	Door Circuit is Open
dSFL	Dryer Sensor Circuit Failure
FAr	Degree in Fahrenheit
FILL	No Cycle in Progress
FLS	Flash Display Active
FrEE	Free Dry Mode
GdLY	Anti-Wrinkle Delay Time
Gont	Anti-Wrinkle On Time
Grd	Anti-Wrinkle Program Active
HICd	High Cool Down
Hot	Overheating Condition
LCC	Left Coin Count
LCdE	Left Coin Denomination
LOCd	Low Cool Down
nbUZ	No Buzzer (Tone)
nFLS	No Flash Display
nGrd	No Anti-Wrinkle
nSEn	No Rotational Sensor Selected
PdrY	Percent Dry
PL	Program Location
PLOC	Program Location Automatic Review
PPCd	Permanent Press Cool Down
PP	Permanent Press
PUSH	Amount to Start has been Inserted Make Temperature Selection
rCC	Right Coin Count
rCdE	Right Coin Denomination
SEFL	Rotational Sensor Circuit Failure
SEn	Rotational Sensor Selected
tFAS	Time For Amount to Start
tInE	Timed Mode

SECTION VI

PHASE 5 SYSTEM DIAGNOSTICS

All major circuits, including door, lint door, lint drawer, microprocessor temperature sensor, heat and motor circuits are monitored. The Phase 5 Dual Microprocessor Controller (DMC) computer will inform the user, via the L.E.D. display and at the outputs of each relay (and door switch circuit) to easily identify failures.

A. Diagnostic (L.E.D. Display) Failure Codes

1. "dOOr" - indicates door or lint drawer switch circuit is open.
 - a. Keyboard entry was made while main door is open or
 - b. There is a fault in the door switch circuit (external of the Phase 5 DMC (computer)).
2. "dSFL" - indicates a fault in the microprocessor temperature sensor circuit.
 - a. If a fault is detected in the microprocessor heat sensor circuit, the L.E.D. display will read "dSFL" and the buzzer (tone) will sound for approximately 5 seconds every 30 seconds until
 - 1) power is corrected or
 - 2) power to dryer is discontinued and the problem is then corrected.

IMPORTANT: The Phase 5 DMC (computer) has its own internal heat sensing circuit fuse protection located on the back side of the Phase 5 DMC (computer). If a "dSFL" condition occurs, check to see if this fuse has blown. If it has, **do not** replace the entire microprocessor controller (computer); **REPLACE ONLY THE FUSE and do so only with a 1/8-Amp (Slo Blo) fuse only.**

NOTE: Once the Phase 5 DMC (computer) detects a problem in the heat circuit, it updates, every 30 seconds, so if the problem was a loose connection in this circuit which corrected itself, the "dSFL" condition would automatically be cancelled.

1. "SEFL"
 - a. Indicates a rotational sensor circuit failure meaning that there is a fault somewhere in the basket (tumbler) rotation detection circuit or, the Phase 5 DMC (computer) program related to this circuit (**PL01**) is set incorrectly in the active mode (SEn) where the dryer is not equipped with the optional rotation sensor and should be set in the inactive mode (nSEn).

NOTE: If the dryer is equipped with the rotational sensor and the display reads "SEFL," reset by closing and opening the Program Switch (PS). Restart the dryer and if the "SEFL" code appears again, investigate further.

4. "Hot"
 - a. Indicates a possible overheating condition. The Phase 5 DMC (computer) monitors the temperature in the dryer at all times. If the Phase 5 DMC (computer) detects that the temperature in the dryer has exceeded 170°F (77°C), it will disable **ALL** the outputs (shut the dryer down), the tone (buzzer) will sound for approximately 5 seconds and the display will read "Hot". The L.E.D. display will continue to read "Hot" until the temperature sensed has dropped to

170°F (77° C) or lower and the Phase 5 DMC (computer is manually reset by closing and opening the Program Switch (PS)).

B. L.E.D. Display Indicators (DOT)

The L.E.D. indicator dots located at the top portion of the display (refer to the illustration on **page 61**) indicate the various microprocessor controller (computer) output functions while a cycle is in progress. These dots **do not** necessarily mean that the outputs are functioning. They are only indicating that the function (output) **should be on.**

1. Heat Circuit Indicator - This indicator dot is on whenever the Phase 5 DMC (computer) is calling for the heating circuit to be on.
2. Motor Circuit Indicator - This indicator dot is on whenever a cycle is in progress.

C. Phase 5 DMC (Computer) Relay Output L.E.D. INDICATORS

There are six (6) L.E.D. indicators (red lights) located on the back side area of the Phase 5 DMC computer (refer to illustration on **page 68**) which are identified or labeled U (upper) and L (lower) for the appropriate circuit (i.e. door, motor, or heat). These L.E.D.'s indicate that the outputs of the Phase 5 DMC (computer), or in the case of the door or lint drawer circuit, the inputs are functioning.

1. **"DOOR"** L.E.D. Indicators
 - a. **Should be on at all times** (even if dryer is not running) unless the main door or lint drawer is open or there is a problem (open circuit) in either of these circuits.

NOTE: If the dryer is started (the display L.E.D. indicator dots are on) and there are no outputs (heat or motor output L.E.D.'s are off) and the appropriate "DOOR" input L.E.D. is on, the fault is in the Phase 5 DMC computer itself.

NOTE: If the failure was elsewhere (i.e. dryers' door or lint drawer circuit) the display would read "door" if a keyboard entry was attempted. If the display L.E.D. indicators are on, and the door L.E.D. input and motor and heat output L.E.D.'s are on and yet the motor or heat is not on; then the problem is not the door switch or the Phase 5 DMC (computer), the problem is elsewhere in the dryer.

2. **"HEAT"** Output L.E.D. Indicator
 - a. If the dryer is started and there is no heat, yet the Phase 5 DMC (computer) display heat circuit indicator dot is on, but the "HEAT" output L.E.D. indicator is off, then the fault is in the Phase 5 DMC (computer) itself. If both the heat indicator dot and the "HEAT" output L.E.D. indicator dots are on, then the problem is elsewhere (i.e. external of the Phase 5 DMC [computer]).
3. **"MOTOR"** Output L.E.D. Indicator
 - a. If the dryer started and the motor is not operating, yet the Phase 5 DMC (computer) display motor circuit indicator dot and "DOOR" input L.E.D. indicator are on, but the motor output L.E.D. indicator is off; then the fault is in the Phase 5 DMC (computer) itself. If the motor is not operating and the "MOTOR" output L.E.D. indicator is on, then the problem is elsewhere (i.e. external of the Phase 5 DMC [computer]).

D. Phase 5 DMC (Computer) Input and Output L.E.D. Indicators

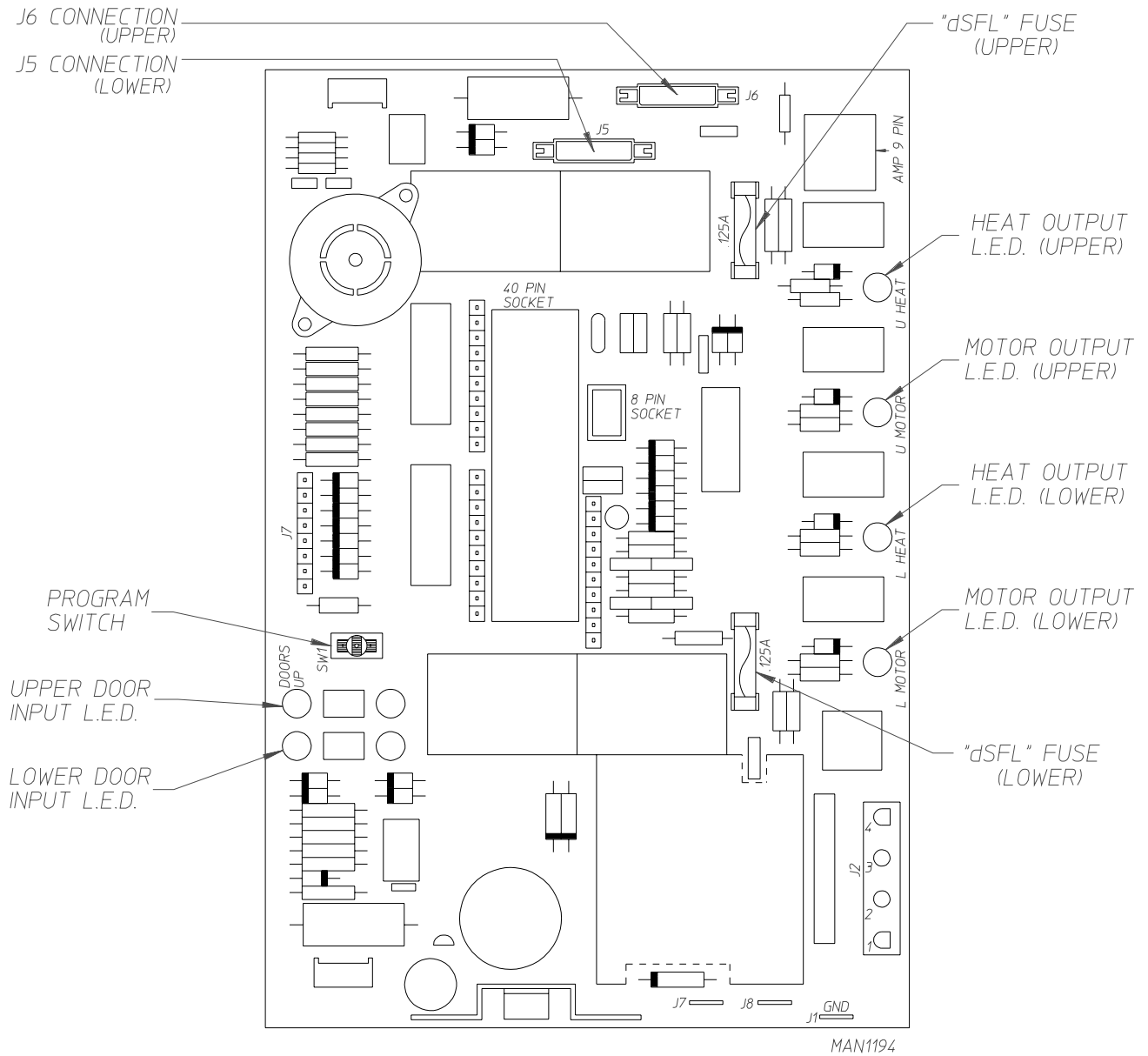

Phase 5 Microprocessor Controller Programming Limits

Program Location	Parameter	Range	Increments
PL02	"PdrY" Auto Cycle percentage of dryness	90% to 100%	1
PL03	"HI" Drying Temperature	110° to 150° F 43° to 66° C	5° 1°
PL04	"HI" Cool Down Temperature "HI" Cool Down Time	70° to 100° F 21° to 38° C 0 to 9	5° 1° 1 minute
PL05	"LO" Drying Temperature	110° to 150° F 43° to 66° C	5° 1°
PL06	"LO" Cool Down Temperature "LO" Cool Down Time	70° to 100° F 21° to 38° C 0 to 9	5° 1° 1 minute
PL07	"PP" Drying Temperature	110° to 150° F 43° to 66° C	5° 1°
PL08	"PP" Cool Down Temperature "PP" Cool Down Time	70° to 100° F 21° to 38° C 0 to 9	5° 1° 1 minute
PL09	"LCdE" Left Coin Denomination	1 to 9999	1
PL10	"rDdE" Right Coin Denomination	1 to 9999	1
PL11	"tFAS" Time for Amount to Start	1 to 99	1 minute
PL12	"AtSt" Amount to Start	1 to 9999	1
PL13	"AFAt" Amount for Additional Time	1 to 9999	1
PL14	"Adrt" Maximum Auto Dry Time	1 to 99	1 minute
PL15	"GdLY" Anti Wrinkle Guard Delay Time "Gont" Anti-Wrinkle Guard On Time	1 to 9 10 to 99	1 minute 1 second
PL16	"AGt" Anti-Wrinkle Guard Active Time	1 to 99	1 minute
PL17	"A" Auto Cycle Factor "B" Auto Cycle Factor	1 to 9 10 to 99	1 1

